

Coupe A - A
1:2

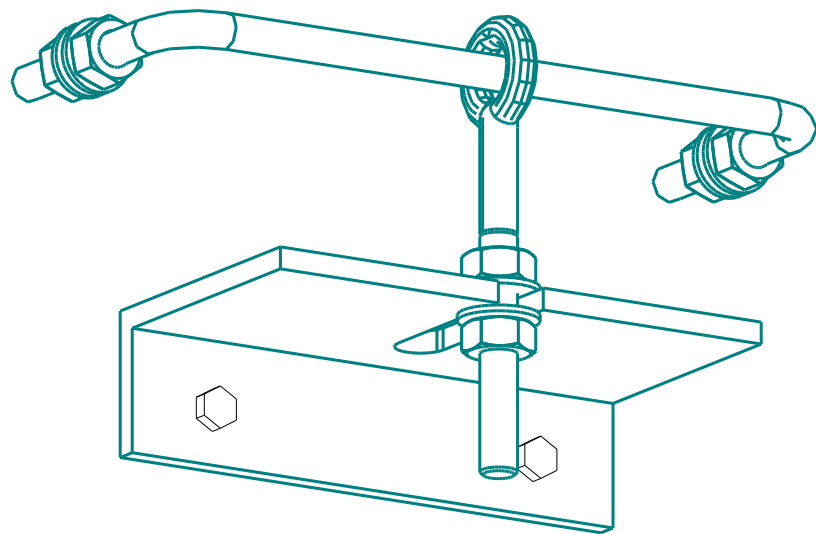

LISTE PAR ASSEMBLAGE Rep: AC01					© All rights reserved			
Nom	Profil	Qté	Matériau	Revêtement	Longueur	Peinture	Poids	
AC01	L80*40*6	1	S235JR	Galvanized	150	0.0	0.8	
ECROU	emile_maurin_2201110	4	S235JR	Galvanized	8	0.0	0.0	
Ecrou poignée	emile_maurin_fix_infra_7861010***	2	S235JR	Galvanized	22	0.0	0.0	
INSERT	piton_314003010	1	S235JR	Galvanized	31	0.0	0.1	
Poignée	ROND10	1	S235JR	Galvanized	332	0.0	0.2	
Rondelle	emile_maurin_7020110	4	S235JR	Galvanized	2	0.0	0.0	

N° Affaire:	2022-01	Indice de révision:	A
Nom Affaire:	Capot Convoyeur Defrance	Date de révision:	26.08.2022
		Date de création:	26.08.2022
		Dessinateur:	S.Defrance



ASSEMBLAGE

